

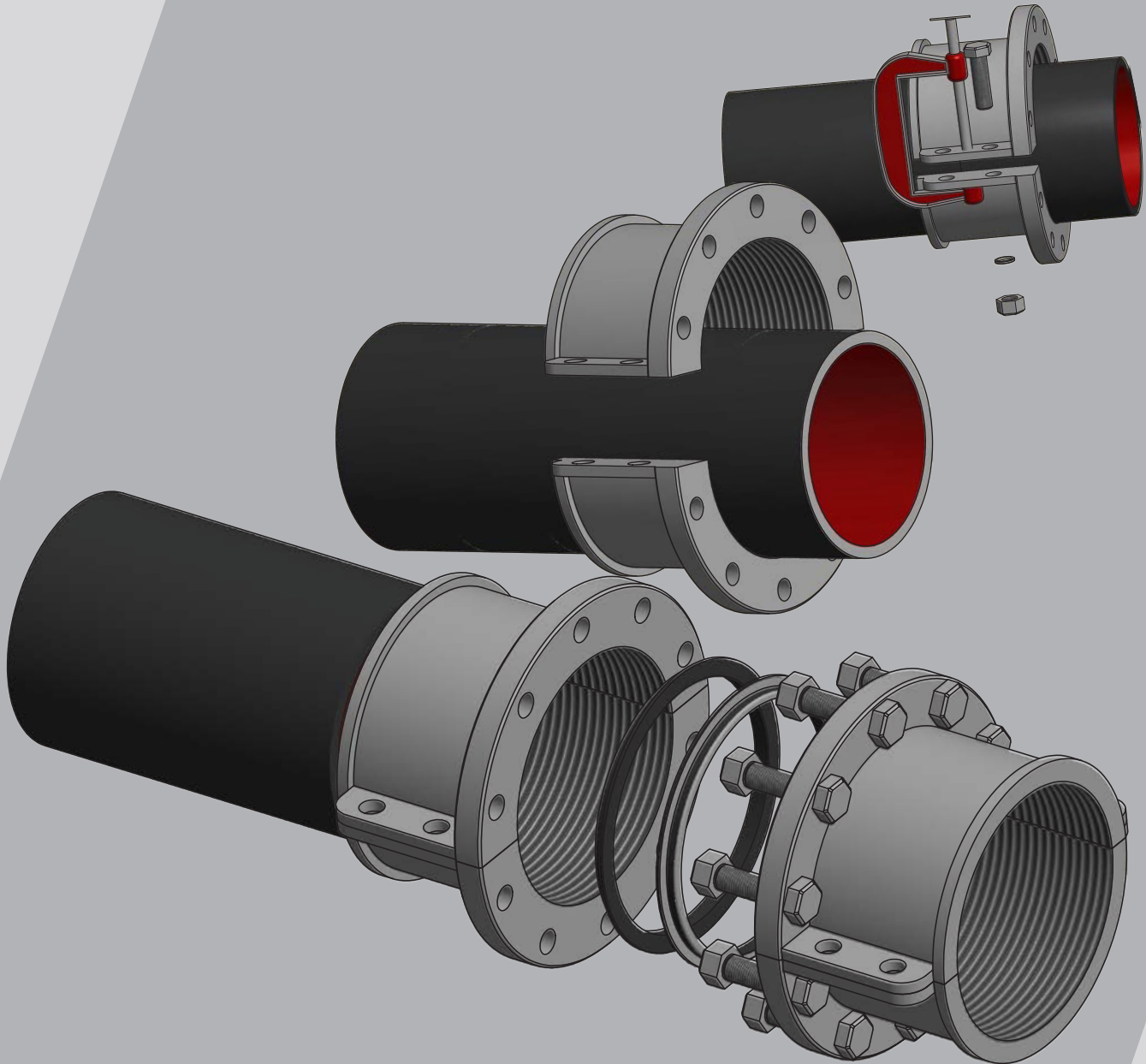

// ONE BRAND // ONE SOURCE // ONE SYSTEM



REMA TIP TOP
PRODUCT INNOVATION 2015

// SERVICE // MATERIAL PROCESSING // SURFACE PROTECTION // AUTOMOTIVE

REMA TIP TOP MATERIAL HANDLING HOSE SYSTEMS



REMA TIP TOP MATERIAL HANDLING HOSE SYSTEMS

Custom-designed wear resistance solutions

REMA TIP TOP offers a wide variety of innovative, high quality products that protect various plants from wear problems and long-term secure their smooth operation. Outstanding among these products and high on demand all over the world is the REMA TIP TOP material handling hose system for slurry transport. A broad and comprehensive range of services precisely tailored to meet our customers' individual requirements complete our offer and make REMA TIP TOP worldwide your reliable expert concerning all aspects of conveyor plant operation.

Slurry handling hoses – a safe connection

Wherever abrasive slurries are hydraulically conveyed safely and at high speed, slurry handling hoses provide a reasonable alternative to steel pipes. Typical fields of application for slurry

handling hoses are mining and steel industry, especially coal preparation plants, and cement industry. Furthermore, slurry handling hoses find application in the mineral processing industry, for example in sand and gravel plants. All these fields of application impose highest demands on a flexible, quick-to-install conveying line. Hassle-free, easily handled slurry handling hoses perfectly meet these demands.

The most important advantage of a slurry handling hose is its special wear-resistant inner tube liner made of natural rubber. It secures an almost vibration-free and relatively silent transport of all conveyed goods. Additionally, compared to a transport via steel pipe it reduces flow resistance and improves the overall flow behaviour. By their high wear resistance, slurry handling hoses provide for a maximum of long-term plant availability. Wear leakages are completely avoided, and so are resulting contaminations as well as expensive system downtimes for their removal

Design of a DUNLOP HD slurry handling hose

1. Wear tube NR, 40 Shore (A)
2. Polyester cord, 2 plies
3. Sandwich rubber
4. Steel spiral
5. Polyester cord, 2 plies
6. SBR cover rubber

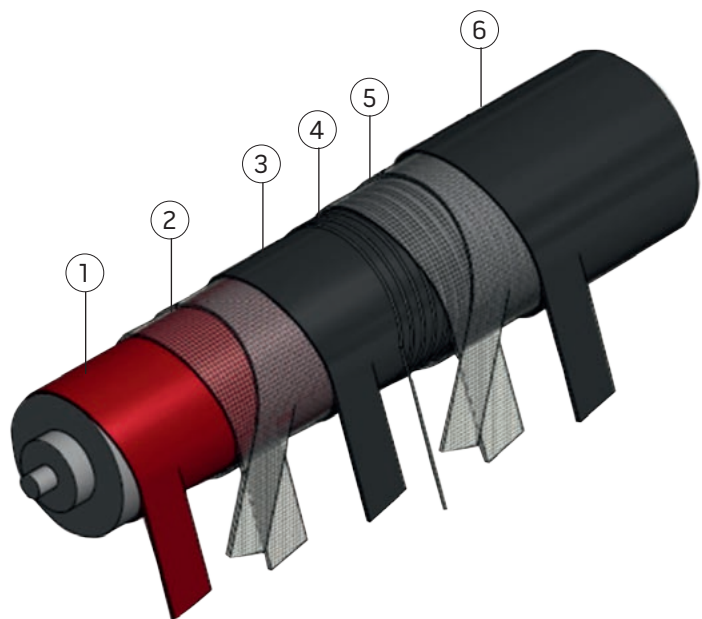

DUNLOP Industrial Products South Africa

REMA TIP TOP South Africa has secured a strong partner on the market by taking a stake in DUNLOP Industrial Products South Africa. REMA TIP TOP has advanced to one of the leading suppliers of slurry handling hoses. The hoses produced by DUNLOP Industrial Products South Africa in accordance with the high REMA TIP TOP quality criteria puts the company in the position of being able to supply clients on any continent with slurry handling hoses that meet or even exceed international standards.

These types of slurry handling hoses are part of the REMA TIP TOP delivery range:

- DUNLOP HD slurry handling hoses for slurry applications,
- DUNLOP HD slurry handling hoses with permanently vulcanized fixed flanges,
- DUNLOP HD slurry handling hoses with ring flanges for higher operation pressures,
- DUNLOP HD softwall slurry handling hoses without inner steel spiral for non wire reinforced application,
- Dredging hoses (customized special products).

REMA TIP TOP MATERIAL HANDLING HOSE SYSTEMS

The REMA TIP TOP material handling hose system

The REMA TIP TOP material handling hose system for abrasive slurries transport consists of the following three easily replaceable standard elements: slurry handling hose, split flange coupling and gasket. The coupling is mechanically fixed to the flexible hose without diminishing the hose's diameter – not even in the coupling's location itself. This ensures that coupling and transported material do not get into contact, which protects the coupling effectively from wear. Furthermore, the flow behaviour stays constant. When the hose needs replacement, the coupling is ready for another use. Its handling is very comfortable as its positioning on the slurry handling hose is very easy: The operator rotates the coupling on the hose until the bores of both flanges are aligned. The REMA TIP TOP material handling hose system is applicable with all internationally established flange-drilling dimensions.

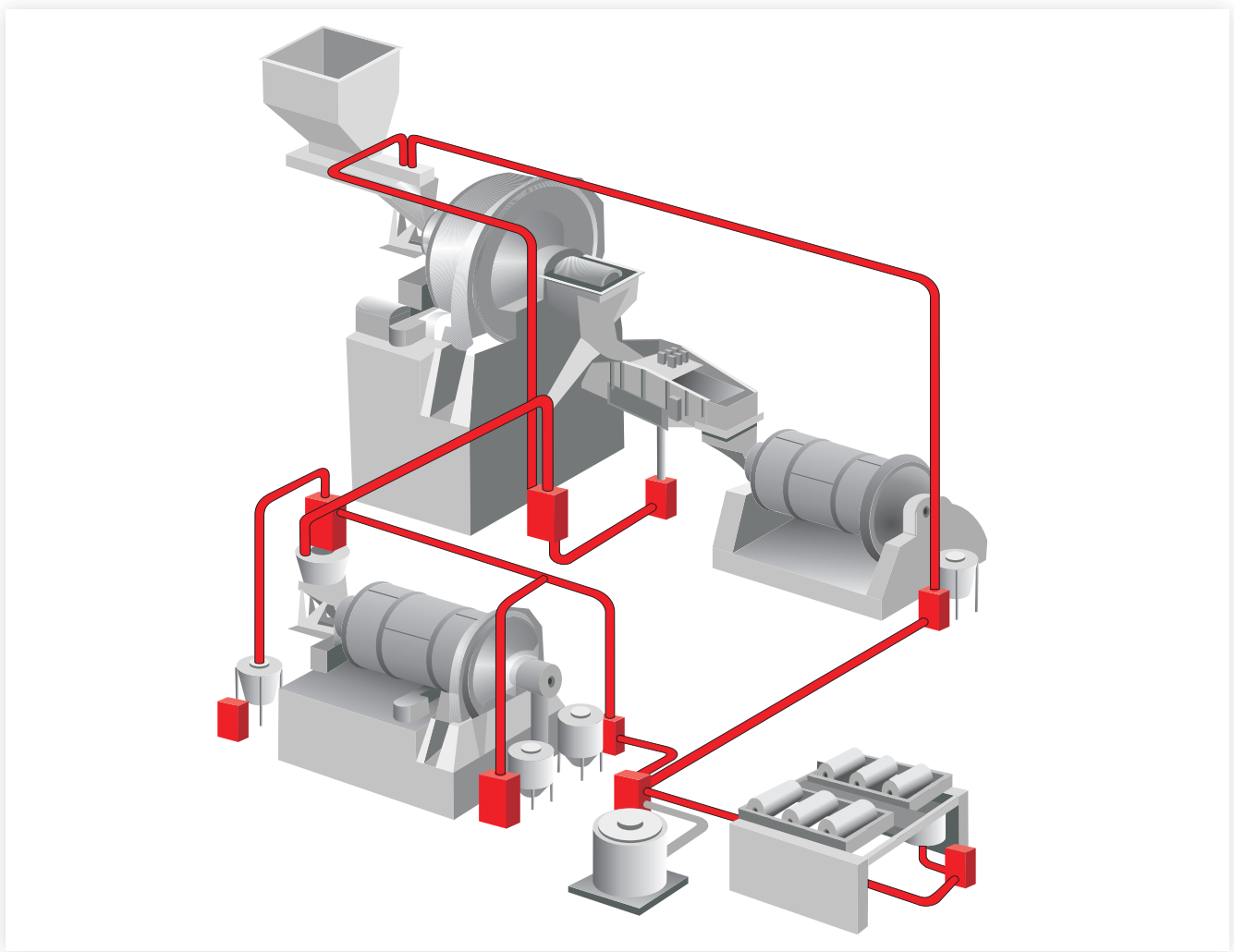

Advantages of the REMA TIP TOP material handling hose systems

- extended life span compared to steel pipe due to inner tube liner made of natural rubber
- reduced flow resistance, absorbed vibration and less noise emissions thanks to smooth inner surface
- weather-resistant and wear-resistant outer layer
- quick and easy mounting, no special tools required
- uncomplicated and flexible adaptation to construction alternations of the plant
- three component system for economic storage
- cost-effective application thanks to building components and reusable couplings

REMA TIP TOP

MATERIAL HANDLING HOSE SYSTEMS: SLURRY HANDLING HOSES

DUNLOP HD slurry handling hoses for hydraulic application

DUNLOP HD slurry handling hoses are designed for high-demand operation conditions and convince by their wear-resistant inner tube liner of about 40 Shore A, by their smooth inner surface and by the low flow resistance they provide. An embedded steel spiral and a special polyester cord additionally strengthen the slurry handling hoses. Their smooth outer surface is highly resistant against wear and weather influences. Combined with two-part REMA TIP TOP couplings and REMA TIP TOP gaskets the DUNLOP HD slurry handling hoses form a reliable, material handling system for all sorts of conveyed goods that is flexible in its length.

Characteristics

- Equipped with red, wear-resistant NR inner tube liner
- Extremely wear- and abrasion-resistant
- Avoids punctual wear and leakages
- Easy, flexible and fast mounting and replacement without any special tools
- Fit for length cutting on location of use
- Usable as pipe bend (depending on bend radius and angle)
- Reduce operation costs
- Long durability
- Noise absorbing
- Vibration absorbing
- Weather resistant
- Marking: red label (Vulkanette)
- Designed for operating temperatures from -35 °C to +70 °C
- Bursting safety factor of 3,2 times the working pressure

Fields of application

- Hydraulic pressure and suction transport of abrasive slurries (stones, gravel and sand of a particle size up to 10 mm)
- Applicable as compensation hoses where steel pipes expand as a result of increased temperatures



Ref. No.	Inner diameter (mm)	Inner diameter (inch)	Outer diameter (mm)	Thickness of inner tube liner (mm)	Minimum bending radius (mm)	Weight (kg/m)	Standard length (m)	Working pressure (MPa)	Vacuum in %
537 8000	76	3.00	99,5	6	450	4,1	20	1	90
537 8001	102	4.00	125	6	600	5,4	20	1	90
537 8002	127	5.00	154	6	750	7,5	10	1	90
537 8003	152	6.00	178	6	900	8,9	10	1	90
537 8004	204	8.00	238	7,5	1 300	16,2	10	1	90
537 8005	254	10.00	291	7,5	1 600	21,3	10	0,7	50
537 8006	305	12.00	341	7,5	1 800	27,5	10	0,7	50
537 8007	355	14.00	403	12	2 200	40,8	10	0,7	50

More dimensions on request.

REMA TIP TOP

MATERIAL HANDLING HOSE SYSTEMS: COUPLINGS

REMA TIP TOP split flange couplings for DUNLOP HD slurry handling hoses

REMA TIP TOP split flange couplings are specially designed as connecting elements for DUNLOP HD slurry handling hoses. The split flange couplings made of high-strength aluminium alloy consist of two or four structurally identical segments for mechanical screw connection to the slurry handling hoses. As they do not get into contact with the transported materials, they are not exposed to any wear and are consequently reusable multiple times.

Characteristics

- No wear applies to the couplings
- Quick and easy installation without any special tools
- Low weight due to high-strength aluminium alloy
- Reduce operation costs because of reusability
- High weather resistance
- Applicable with all established flange-drilling dimensions (DIN, ANSI)

Fields of application

- Connecting element for DUNLOP HD slurry handling hoses and hose bends with highest wear demands

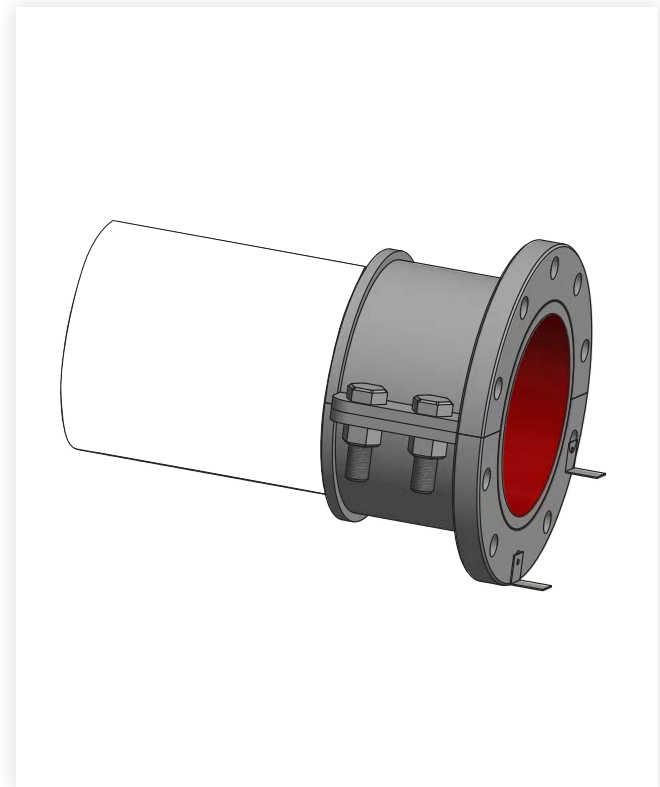

Ref. No.	Size in mm	Size in Inch	For Hoses with ID in mm	OD Coupling in mm	PCD min. - max. in mm	Number of holes (pieces)	Number of segments (pieces)	Weight in kg/pce	Applicable with standard flange drilling dimensions					
									DIN 2632	BS10	BS4504		SABS 1123	ASME/ANSI
									PN10		10/3	16/3	1000/3	B16.1
537 8100	76	3"	76	195	147-171	4	2	1,7	x	x	-	x	x	x
537 8101	102	4"	102	217	178-192	4	2	2,7	x	x	-	x	x	x
537 8102	127	5"	127	254	200-229	8	2	3,5	x	x	-	x	x	x
537 8103	152	6"	152	278	235-250	8	2	5,3	x	x	x	x	x	x
537 8104	204	8"	204	338	295-310	8	2	9,4	x	x	x	x	x	x
537 8105	254	10"	254	402	350-374	8	2	11,5	x	x	x	x	x	x
537 8106	305	12"	305	477	400-445	12	2	17	x	x	x	-	x	-
537 8107	355	14"	355	526	445-470	12	4	22,5	x	x	x	-	x	-

More dimensions and alloys on request.

REMA TIP TOP

MATERIAL HANDLING HOSE SYSTEMS: GASKETS

REMA TIP TOP gaskets for DUNLOP HD slurry handling hoses

REMA TIP TOP slurry handling hose gaskets made of high quality polyurethane are specially designed for DUNLOP HD slurry handling hoses. Combined with REMA TIP TOP split flange coupling they form a secure connection to prevent leakages between hose parts, hose bends, slurry handling hoses and rubber-lined pipes.

Characteristics

- Avoid turbulences
- Quick and easy installation without any special tools
- Low weight
- High resistance against chemicals

Fields of application

- Gasket for REMA TIP TOP split flange couplings to combine with DUNLOP HD slurry handling hoses and hose bends

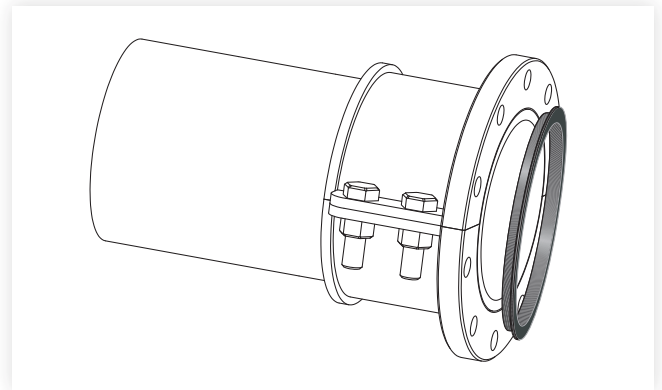

Ref. No.	Size (mm)	Size in Inch	For hoses with inner diameter of (mm)	Weight (kg/piece)
537 8200	76	3"	76	0,1
537 8201	102	4"	102	0,15
537 8202	127	5"	127	0,2
537 8203	152	6"	152	0,25
537 8204	204	8"	204	0,4
537 8205	254	10"	254	0,6
537 8206	305	12"	305	0,7
537 8207	355	14"	355	0,75

More dimensions on request.

REMA TIP TOP

MATERIAL HANDLING HOSE SYSTEMS: ACCESSORY COMPONENTS

3D hose bends

- Equipped with a long-life inner tube liner made of natural rubber, wear thickness of 9-12 mm
- Additional wear thickness on outer bend available
- Designed according to individual specifications and customer requirements
- Suitable for REMA TIP TOP aluminium split flange couplings, therefore easy installation
- Applicable as connecting elements for pipes and bends when a preformed hose is required, especially for installation in confined spaces
- Dimensions on request



Reducers

- Rubber lined steel reducers
- Applicable as connecting elements between pipes and conveying hoses with different diameters
- Available with a 9-12 mm long-life rubber compound wear protection
- Designed and lined according to individual specifications and customer requirements
- Dimensions on request



Y-Pieces

- Y-Pieces or branch pipes for applications with high wear stress and strong abrasion
- Made of steel and lined with an inner tube liner of natural rubber
- Steel surfaces protected against corrosion by rubber coatings
- Dimensions on request



Mounting clamps

- Mounting clamps for a secure fixation of DUNLOP HD slurry handling hoses to the supporting construction
- Reduce vibrations of the complete plant
- Mounting clamps made of steel and equipped with corrosion protection





Your local contact



// ONE BRAND // ONE SOURCE // ONE SYSTEM

- // SERVICE
- // MATERIAL PROCESSING
- // SURFACE PROTECTION
- // AUTOMOTIVE

REMA TIP TOP AG
Gruber Strasse 65 · 85586 Poing / Germany
Phone: +49 8121 707-0
Fax: +49 8121 707-10 222
info@tiptop.de
www.rema-tiptop.com



5821741 - X.15 Printed in Germany

